

For Racing Use Only

YOSHIMURA



SUZUKI

GSXR750

HOP-UP KIT MANUAL

USE THIS MANUAL WITH: GSX-R750 SERVICE MANUAL
(Part No. 99500-37030-01 E)

*Before performing any servicing, please read thoroughly GSX-R750 service manual.

MANUFACTURE'S EXEMPTION

SUZUKI GSX-R750 HOP-UP KIT is a special-purpose designed for exclusive use in competition only on racing course as distinguished from public road and highways. GSX-R750 HOP-UP KIT is not equipped for conformity with traffic law and regulations, and is not accorded with the benefit of product which SUZUKI standardly grants on motorcycle of its manufacture.

NOTE:

- * *The GSX-R750 Engine has been developed to increase horse power by adopting the HOP-UP KIT.*
- * *The motorcycle on which the HOP-UP KIT is installed, is not covered by the SUZUKI WARRANTY.*
- * *This HOP-UP KIT manual describes only service specifications and servicing procedures which differ from those of the GSX-R750 service manual.*
- * *Please refer to the GSX-R750 service manual for details.*

CONTENTS

SPECIFICATIONS	1
GENERAL INFORMATION	2
FUEL AND OIL RECOMMENDATIONS	2
BREAK-IN PROCEDURE	2
SPECIAL TOOL	2
HOP-UP KIT INSTALLATION AND SERVICING	3
CRANKSHAFT AND CONROD	3
TRANSMISSION AND CLUTCH	4
PISTON	7
CYLINDER HEAD	7
VALVE SPRING SET LENGTH ADJUSTMENT	
PISTON-CYLINDER HEAD CLEARANCE ADJUSTMENT	
VALVE TIMING ADJUSTMENT	9
PISTON-VALVE CLEARANCE	
MEASUREMENT	11
COMPRESSION RATIO	12
CARBURETOR SETTING	13
SERVICE DATA	14
SERVICING INFORMATION	17

SPECIFICATIONS

ENGINE

Type.....	Four-stroke, liquid-cooled, DOHC, TSCC
Number of cylinders	4
Bore	70.0 mm
Stroke.....	48.7 mm
Piston displacement	749 cm ³
Compression ratio.....	For Sprint 12.5 : 1 For Endurance 12.0 : 1
Intake valve diam.	26 mm
Exhaust valve diam.	24 mm
Intake valve lift.....	9.0 mm
Exhaust valve lift	8.5 mm
Lubrication system.....	Wet sump
Carburetor.....	MIKUNI VM33, four
Spark plug	N.D: X32EPT

TRANSMISSION

Clutch.....	Dry multi-plate type Wet multi-plate type
Transmission	6-speed constant mesh
Gearshift pattern	1-down, 5-up
Primary reduction	1.744 (75/43)
Final reduction	3.000 (42/14) 2.800 (42/15) 2.625 (42/16)
Gear ratios, Low	2.266 (34/15)
2nd.....	1.882 (32/17)
3rd	1.631 (31/19)
4th	1.450 (29/20)
5th	1.315 (25/19)
Top.....	1.200 (24/20)
Drive chain	TAKASAGO: RK50HFO

GENERAL INFORMATION

FUEL RECOMMENDATION

Use racing gasoline or high-octane gasoline (octane rate more than 98).

ENGINE OIL RECOMMENDATION

MOTUL 300V

KVAS MAXIMAL

BREAK-IN PROCEDURE NEW ENGINE

Keep to these break-in engine speed limits:

Up to 100 km	Below 5000 r/min.
Up to 200 km	Below 6000 r/min.
Up to 300 km	Below 7000 r/min.

NOTE:

After this initial run, retighten bolts and nuts and listen into the engine for abnormal noise, inspecting the machine for signs of trouble.

SPECIAL TOOL

1. VALVE TIMING WHEEL

This tool is used for checking the valve timing.

09918-62710

Valve timing wheel

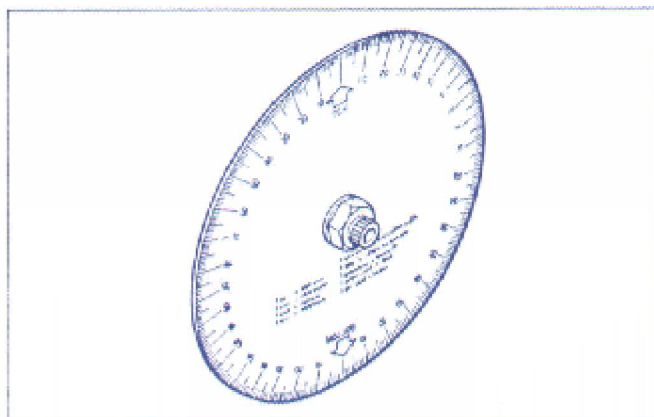

2. TIMING GAUGE

This tool is used for checking the valve timing.

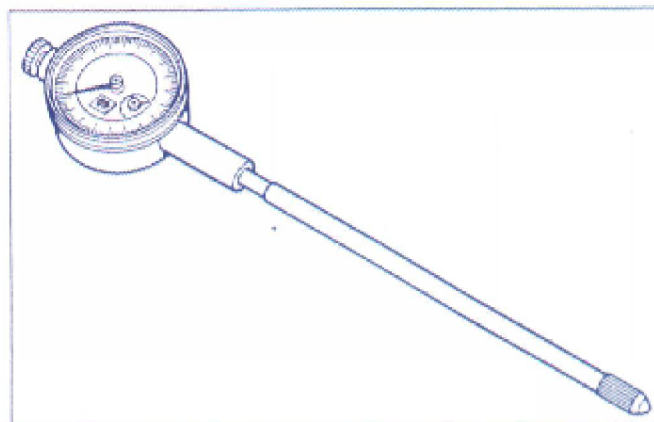

3. CLUTCH SLEEVE HUB HOLDER

(Use for Dry clutch type)

This tool is used for loosening or tightening the clutch sleeve hub nut.

Procure a replacement driven plate, and weld the stay, as shown in the illustration.

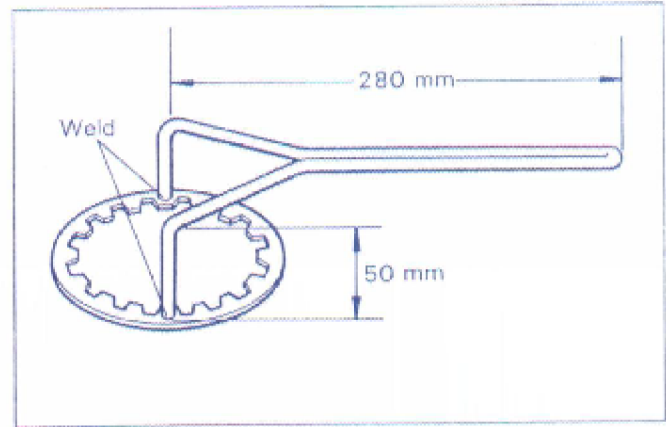

HOP-UP KIT INSTALLATION AND SERVICING

* ENGINE REMOVAL AND REINSTALLATION

(Refer to the GSX-R750 Service Manual page 3-3)

* ENGINE DISASSEMBLY

(Refer to the GSX-R750 Service Manual page 3-12)

* ENGINE COMPONENTS INSPECTION AND SERVICING

(Refer to the GSX-R750 Service Manual page 3-24)

* ENGINE REASSEMBLY

(Refer to the GSX-R750 Service Manual page 3-57)

CRANKSHAFT AND CONROD

- Both crank journal and crank pin bearings are able to use the standard bearings. According to the code numbers on the crankcase, crankshaft and conrod, select the proper size bearings from the selection tables.
- Check the oil clearances with plastigauge.

NOTE:

Always keep the standard oil clearance.

(Refer to pages 3-41 through 3-46 for details)

(Refer to pages 3-59 and 60 for details)

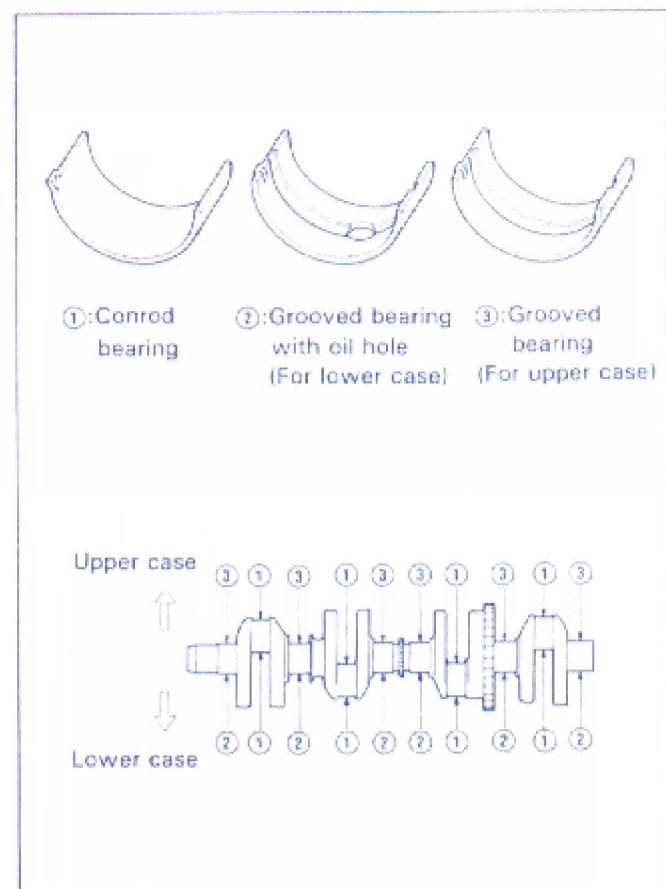

(For Sprint)

- It is unnecessary to install the starter clutch and starter motor when reassembling the engine.
- Press-fit an appropriate plug ① to the oil hole and install the starter clutch mounting bolt ② to the left end of the crankshaft.
- Press-fit the starter motor hole plug to the starter motor hole of the crankcase.

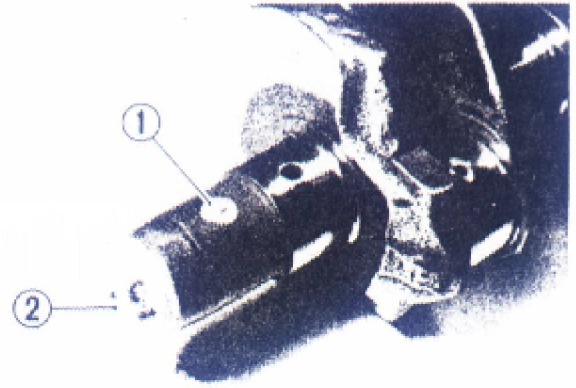

TRANSMISSION AND CLUTCH (Refer to pages 3-51 through 3-58 for details)

- Assemble the transmission and clutch, as shown in the following illustrations.

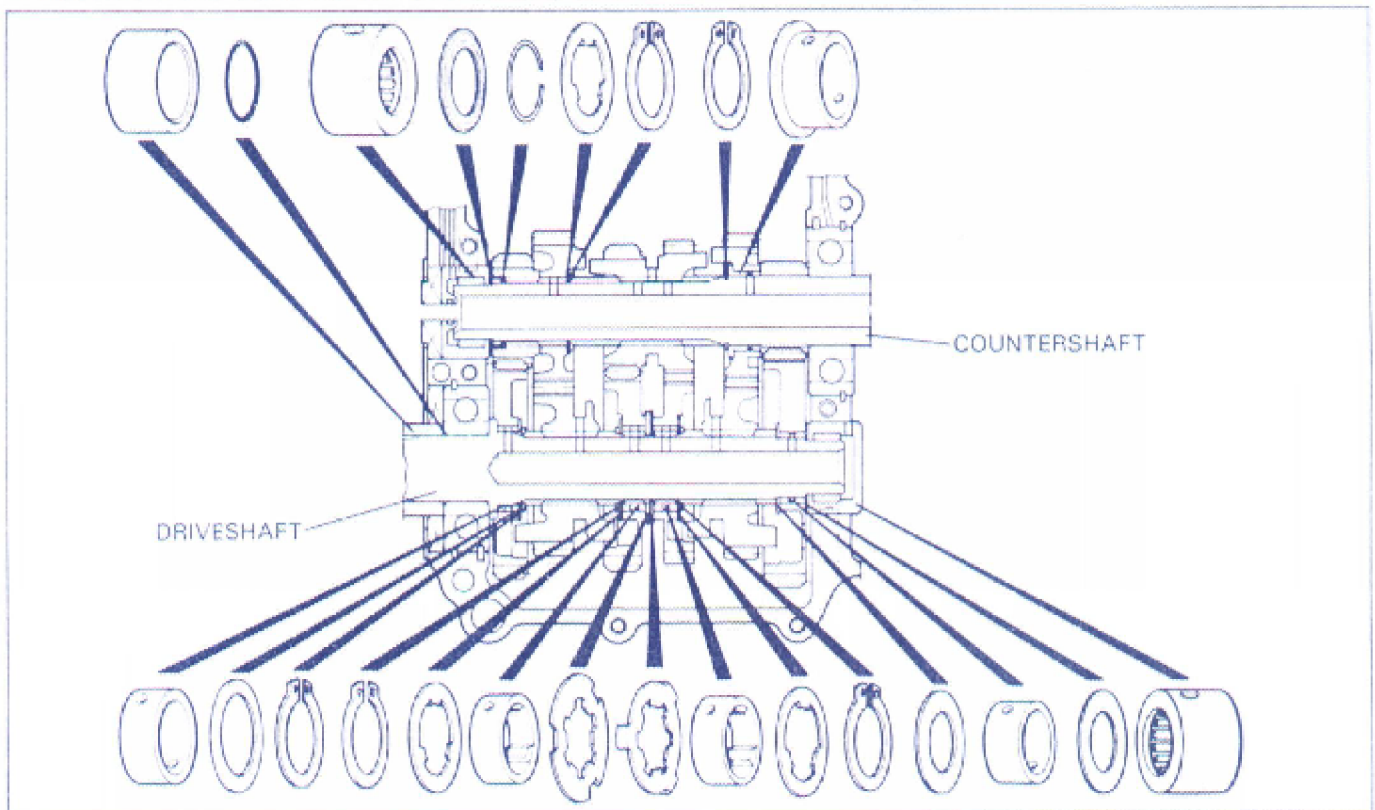

(For Sprint)

- It is unnecessary to install the generator when reassembling the engine.
- Install the generator hole plug with O-ring to the generator hole of the crankcase.

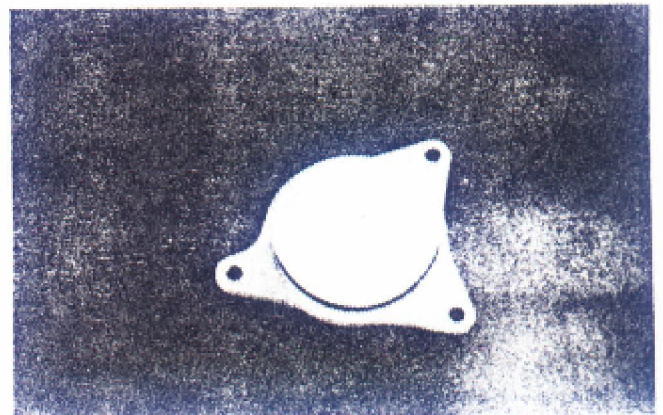

(For Dry clutch type)

* (For Endurance)
Use the generator/oil pump drive gears of standard.

* (For Sprint)
Use the oil pump drive gear only.

Clutch plates:
Drive plate (6 pcs)
Driven plate (7 pcs)

Tightening torque
50 – 70 N·m
(5.0 – 7.0 kg·m)

Tightening torque
11 – 13 N·m
(1.1 – 1.3 kg·m)

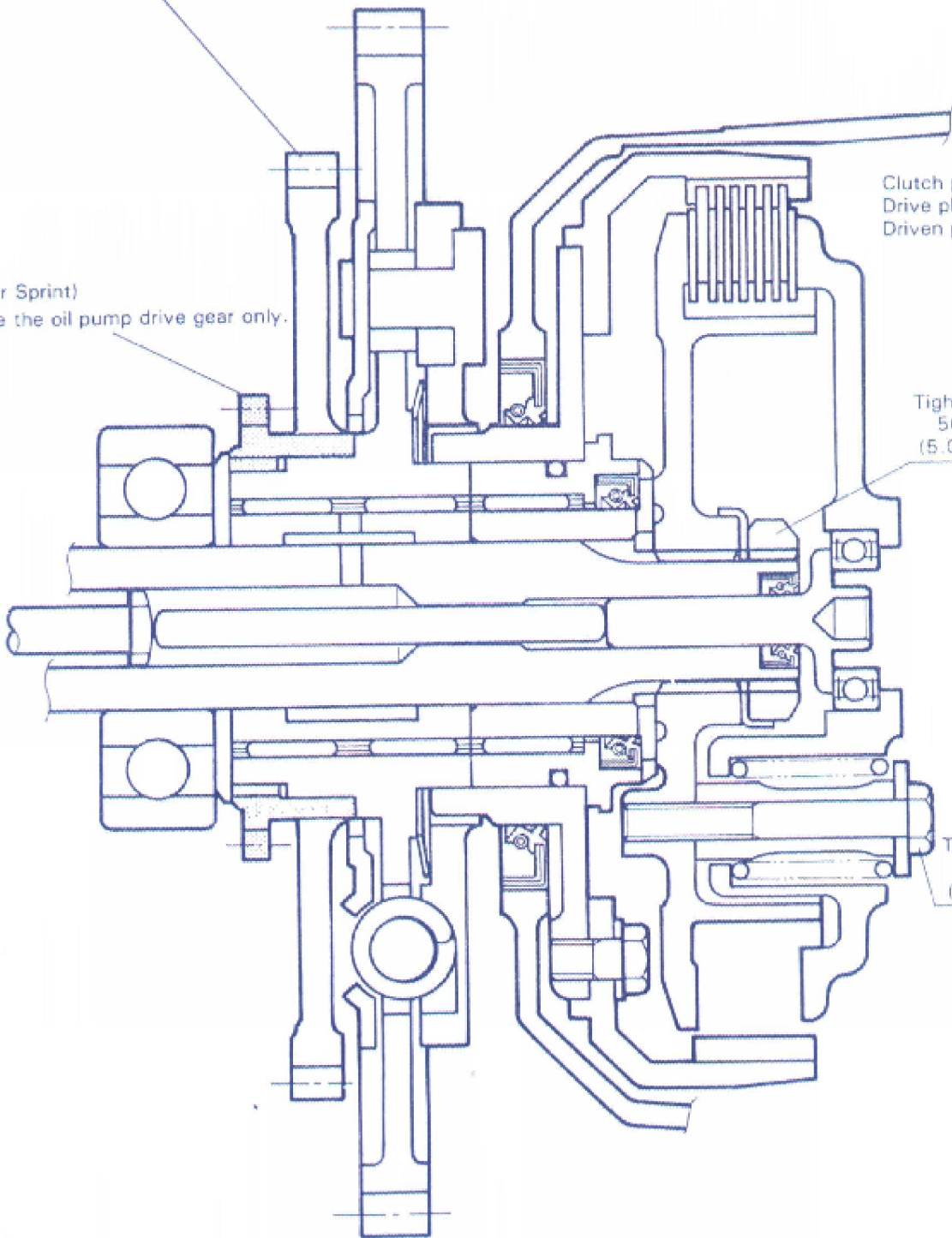

(For Wet clutch type)

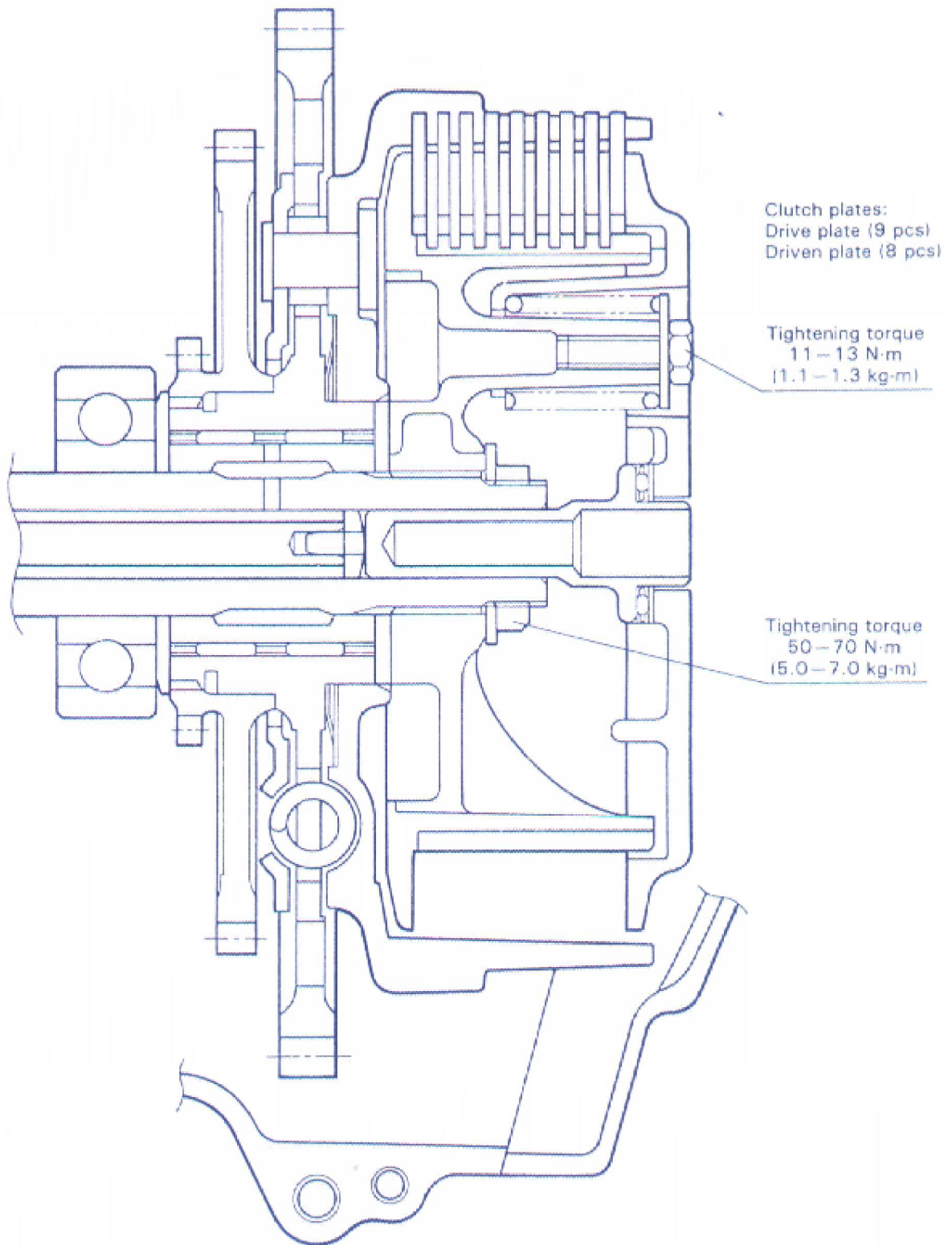

PISTON

- The following three sizes of the piston are used. They bear the following identification marks.

PISTON SIZE	COLOR	PROPER CYLINDER BORE SIZE
69.965 – 69.970 mm	Red	70.020 – 70.025 mm
69.960 – 69.965 mm	Yellow	70.015 – 70.020 mm
69.955 – 69.960 mm	Blue	70.010 – 70.015 mm

- Hone the cylinder bores by honing machine in accordance with the piston sizes.

Piston/Cylinder clearance
0.05 – 0.06 mm

PISTON RING

- Specification of the piston rings are same as standard engine.

(Refer to pages 3-37 through 3-40 for details)

(Refer to pages 3-68 through 3-70 for details)

CYLINDER HEAD

VALVE SPRING SET LENGTH ADJUSTMENT

- Set the valve to the cylinder head, and measure the length Y_1 , as shown in the Fig. 1.
- Set the valve spring retainer and two cotter halves to the valve stem end, and measure the length Y_2 , as shown in the Fig. 2.
- Calculate the valve spring set length X , as shown in the Fig. 3.

$$X = (Y_1 + Y_2) - (Y_3 + Y_4)$$

$$X = \text{Set length, } Y_3 = 2.0 \text{ mm, } Y_4 = 0.8 \text{ mm}$$

NOTE:

When measuring the above spring set length, do not install the valve springs.

Valve spring set length	$32 \pm 0.2 \text{ mm}$
-------------------------	-------------------------

- If the valve spring set length is not within the specification, adjust it with the spring seat shim.

Spring seat shim size (Two kinds)	0.50 mm
	0.75 mm

(Refer to pages 3-24 through 3-36 for details)

(Refer to pages 3-71 through 3-77 for details)

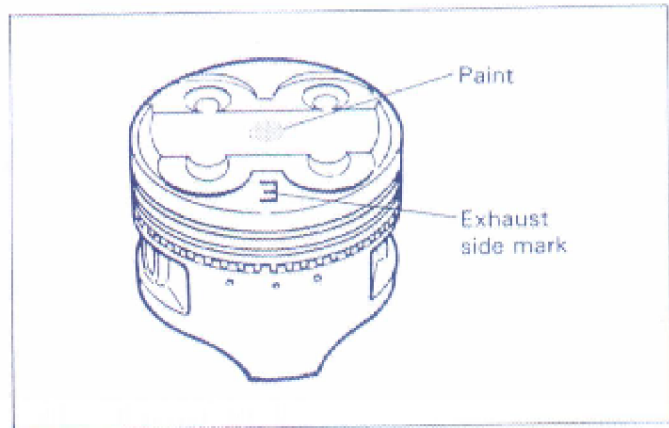

- The piston color is painted on the piston head.

CAUTION:

Be sure to keep the Piston/Cylinder clearance.

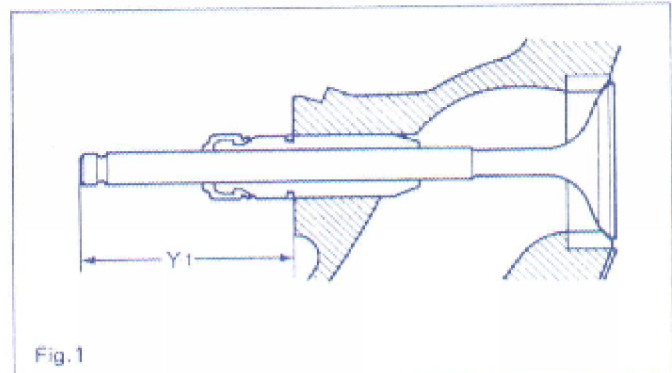

Fig. 1

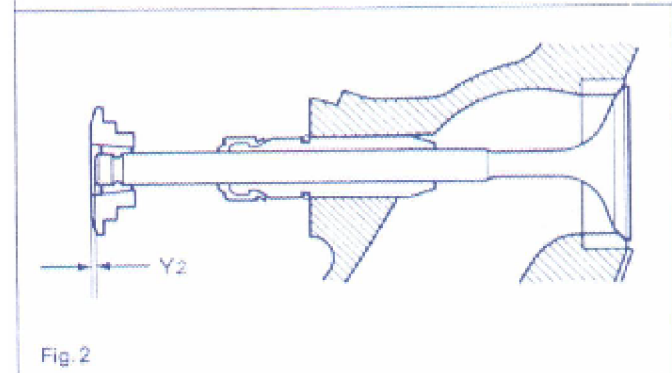

Fig. 2

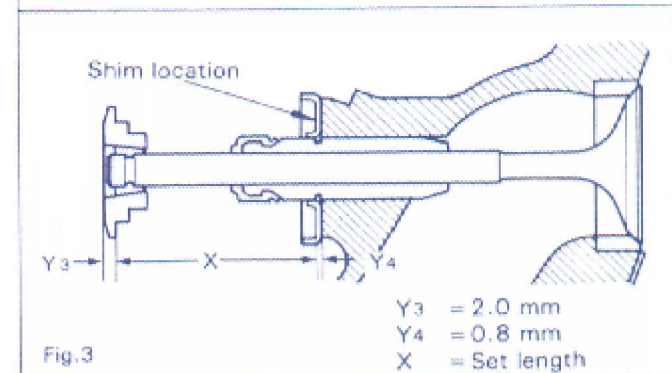

Fig. 3

$$Y_3 = 2.0 \text{ mm}$$

$$Y_4 = 0.8 \text{ mm}$$

$$X = \text{Set length}$$

PISTON-CYLINDER HEAD CLEARANCE (SQUISH HEIGHT) ADJUSTMENT

- After tightening the cylinder head nuts and bolt, measure the piston-cylinder head clearance (squish height) by using (approx. 1.6 mm diam. solder), as shown in the illustration.
- Insert the solder from spark plug hole and turn the crankshaft.
- Measure the thickness of solder with the vernier calipers.

NOTE:

When inserting the solder from spark plug hole, the piston must be at B.T.D.C on the compression stroke.

Piston-cylinder head clearance (squish height) specification

For Sprint	1.0—1.1 mm
For Endurance	1.1—1.2 mm

- If the piston-cylinder head clearance is not within the specification, adjust the clearance by changing the cylinder head gasket or cylinder base gasket.

NOTE:

When changing the gasket and O-rings, measure the thickness of gasket and O-rings. Using the STD gasket as a guide, adjust the clearance by referring to the chart at right.

VALVE TIMING ADJUSTMENT

Adjust the valve timing in the following manner:

NOET:

After installing the camshafts, cam chain idler and cam chain tensioner, be sure to adjust the valve clearance.

*IN. 0.17—0.20 mm (When engine is cold state.)

*EX. 0.19—0.23 mm (When engine is cold state.)

(Refer to pages 3-72 through 3-75 for details)

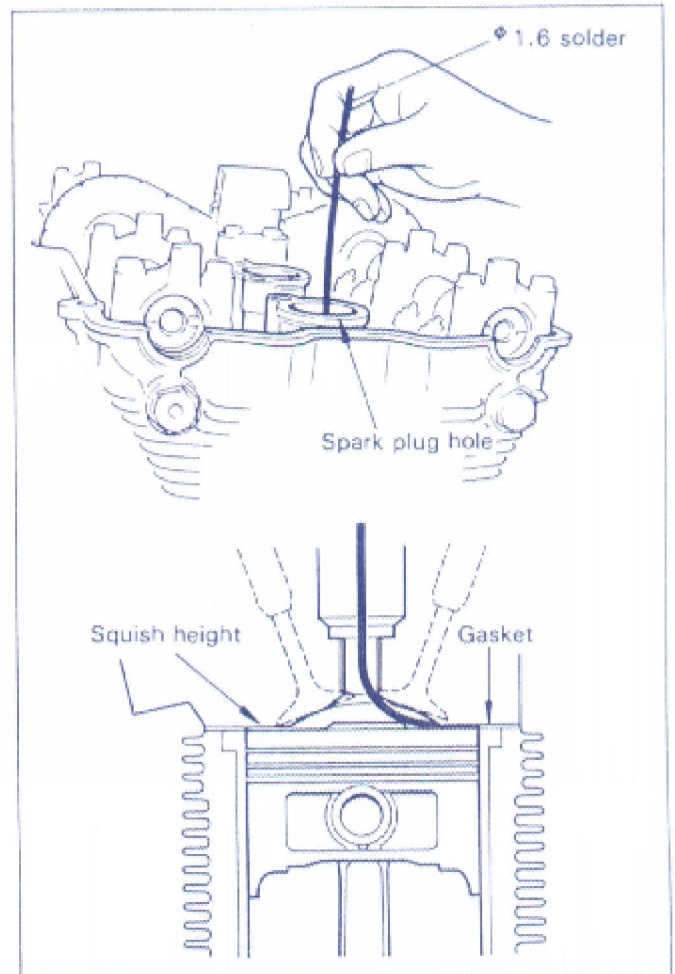

List of gaskets

	Part No.	Thickness
Head gasket with O-rings	Standard (11141-27A01) Head gasket (09280-12008) O-ring	0.65 mm
	YRD-27830 (Head gasket set)	0.85 mm
	YRD-27830 (Head gasket set)	1.05 mm
Base gasket	Standard 11241-27A02	0.3 mm
	YRD-27A50	0.4 mm (0.2 mm × 2)
	YRD-27A60	0.6 mm (0.2 mm × 3)

- Set the valve timing wheel to the right end of the crankshaft.
- Set the timing gauge to the NO.4 spark plug hole.
- Bring the NO.4 piston at T.D.C. on the compression stroke, and set the indicator of the timing gauge to "0" mm by turning the dial.
- Under the above conditions, align the "TOP" mark on the valve timing wheel with the appropriate pointer ①, as shown in the illustration.

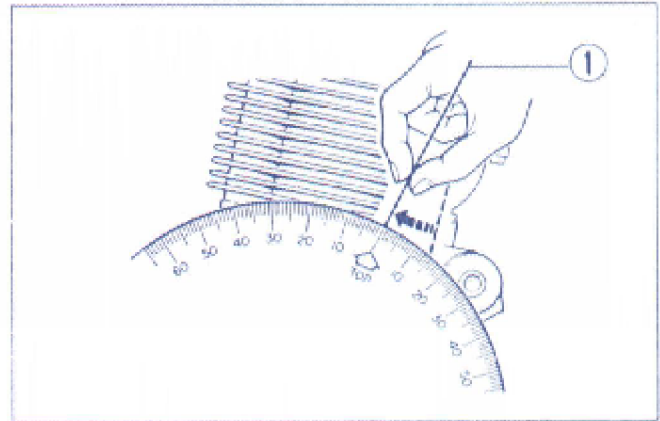
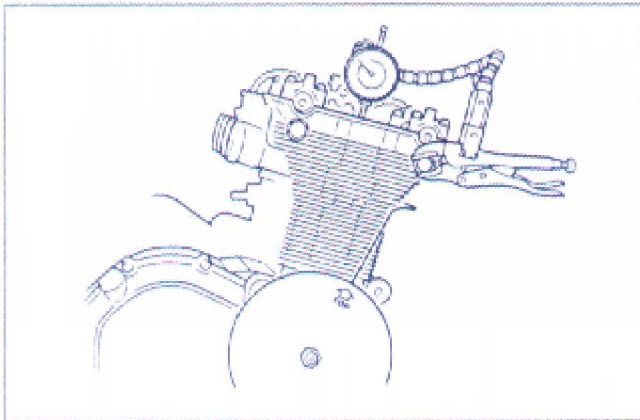
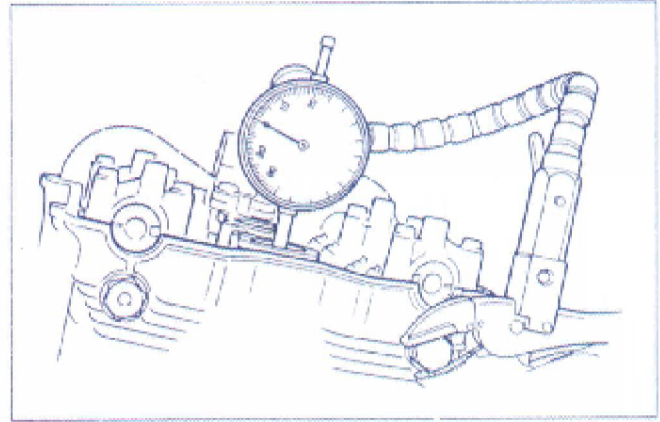

- Set the timing gauge to the EX. side of the valve spring retainer straightly, as shown in the illustration.
- Gently turn the crankshaft clockwise until the timing gauge is read 1 mm and check the EX. valve opening angle.

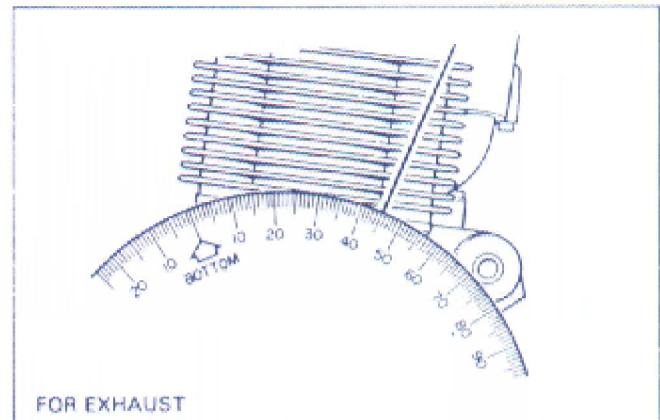
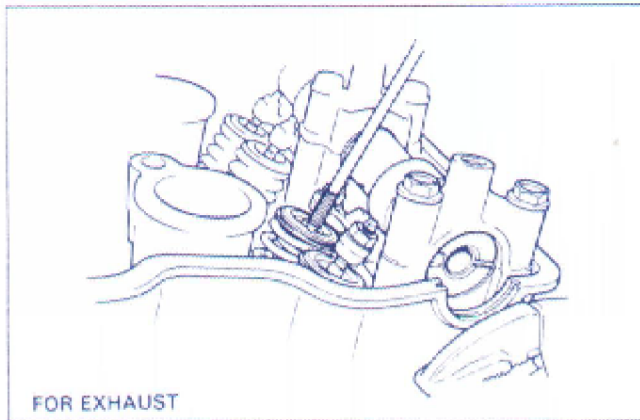
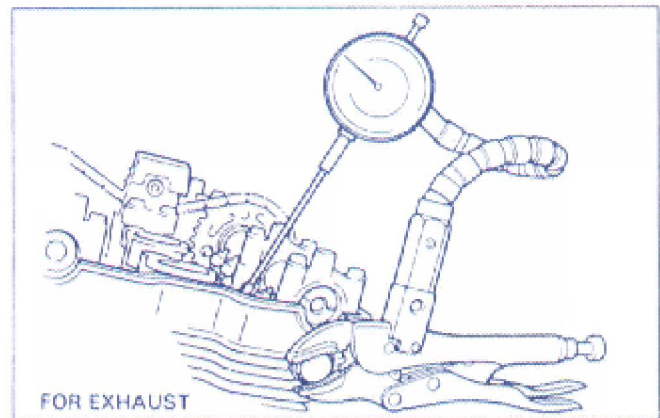

- Select the EX. valve opening angle by loosening the cam sprocket bolts and turning the crankshaft in accordance with the following specification. **(Stage One Cam)**

EX. Valve timing (When valve lift is 1 mm)

For Sprint	For Endurance
EX. Open B.B.D.C. 45°	EX. Open B.B.D.C. 47.5°
EX. Close A.T.D.C. 20°	EX. Close A.T.D.C. 17.5°

EX. Valve lift	8.5 mm
----------------	--------

- After adjusting the EX. valve opening angle, apply **THREAD LOCK SUPER "1303"** to the cam sprocket bolts and tighten them to the specified torque.

Tightening torque	24–26 N·m (2.4–2.6 kg·m)
-------------------	-----------------------------

NOTE:

The intake valve opening angle adjustment procedure is the same as that of the exhaust one.

IN. Valve timing (When valve lift is 1 mm)

For Sprint	For Endurance
IN. Open B.T.D.C. 22°	IN. Open B.T.D.C. 20°
IN. Close A.B.D.C. 42°	IN. Close A.B.D.C. 44°

IN. Valve lift	9.0 mm
----------------	--------

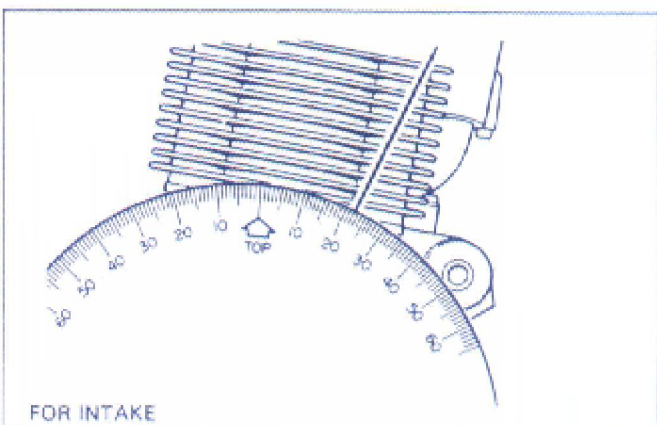
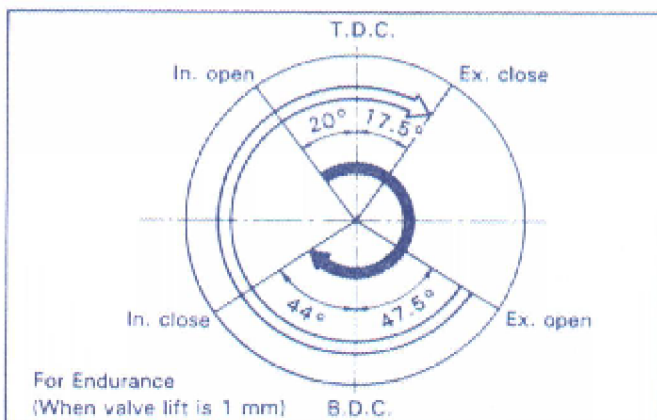
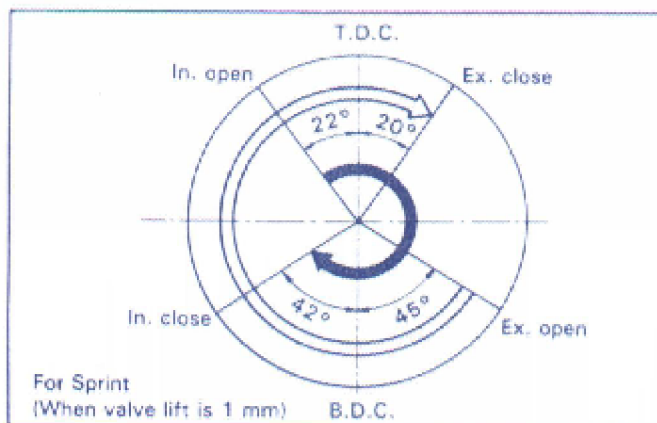
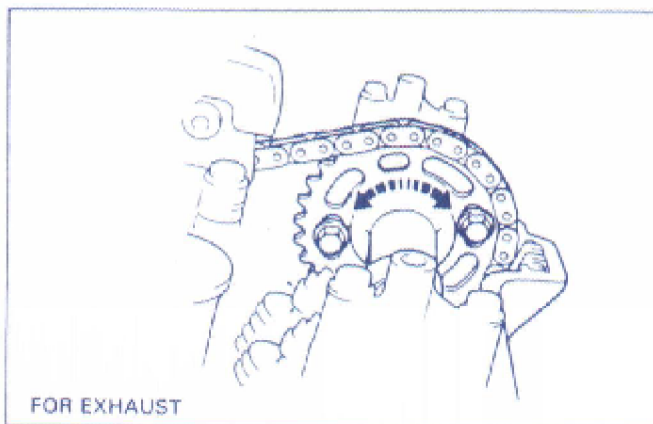
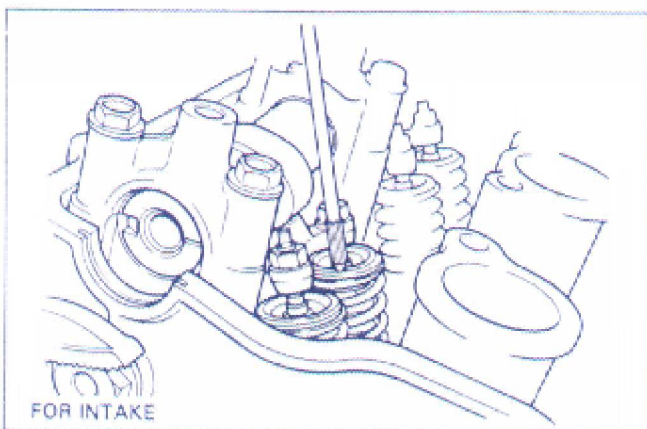

PISTON-VALVE CLEARANCE MEASUREMENT

NOTE:

After adjusting the IN. and EX. valve timing, measure the IN. and EX. piston-valve clearance.

FOR EXHAUST

- Measure each piston-valve clearance for exhaust with the valve timing wheel, timing gauge and valve lifter (or screw driver).
- Set the piston to B.T.D.C. 10° on the overlap condition, and then push down the EX. valve with the valve lifter or screw driver until the valve touches the piston crown and read the timing gauge.
- If the piston-valve clearance is not within the specification, adjust it by changing the head gasket.

SPECIFICATION FOR EXHAUST

Standard	Limit
1.7–2.0 mm	Less than 1.7 mm

NOTE:

- * The piston-intake valve clearance measurement procedure is the same as that of the exhaust one.
- * For piston-intake valve clearance, the piston must be set at A.T.D.C. 10° on the overlap condition.

SPECIFICATION FOR INTAKE

Standard	Limit
0.8–1.2 mm	Less than 0.8 mm

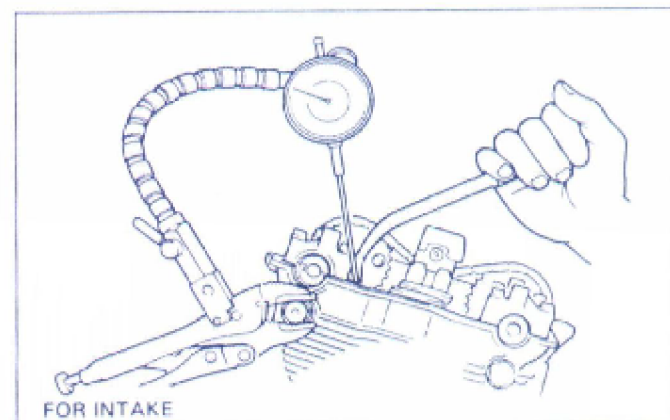
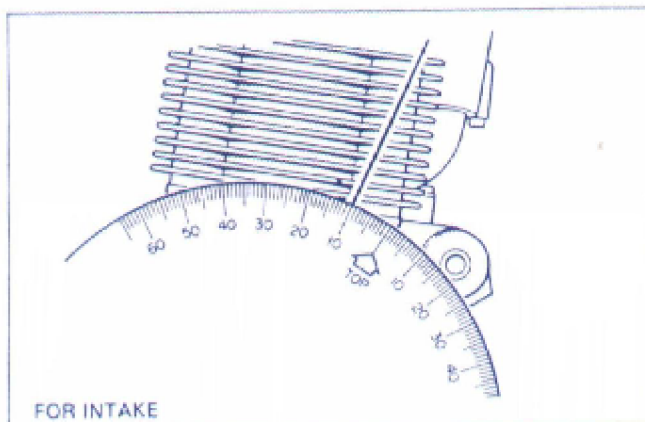
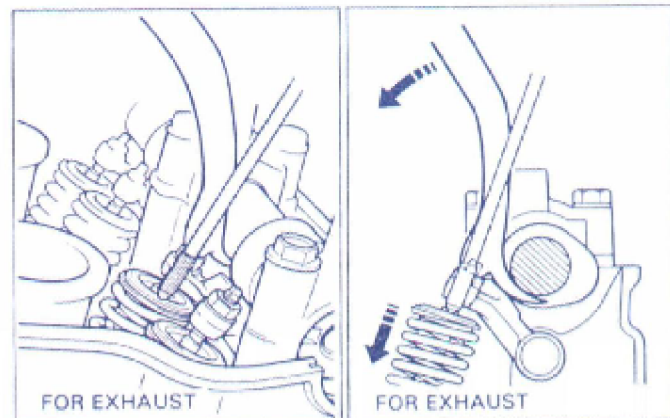
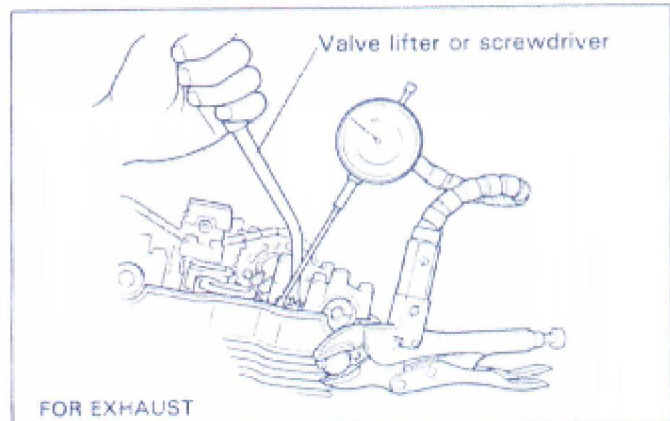
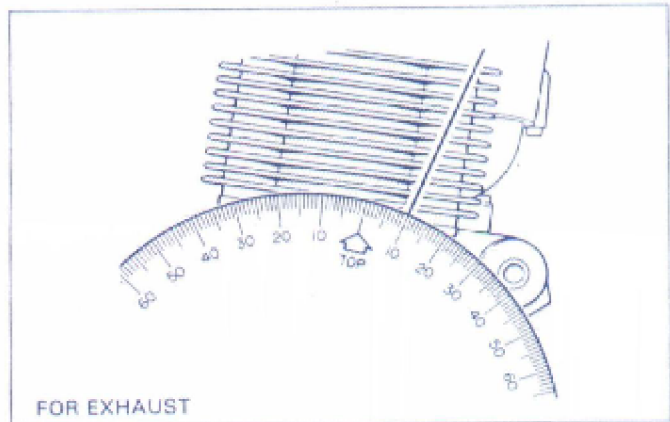

COMPRESSION RATIO

- Set the piston at T.D.C. on the compression stroke and measure each combustion chamber bolume with the burette and kerosene. Calculate the compression ratio.

NOTE:

After measuring the combustion chamber bolume, be sure to drain out kerosene.

COMBUSTION CHAMBER BOLUME

For Sprint	16.3 CC
For Endurance	16.9 CC

COMPRESSION RATIO

For Sprint	12.5: 1
For Endurance	12.0: 1

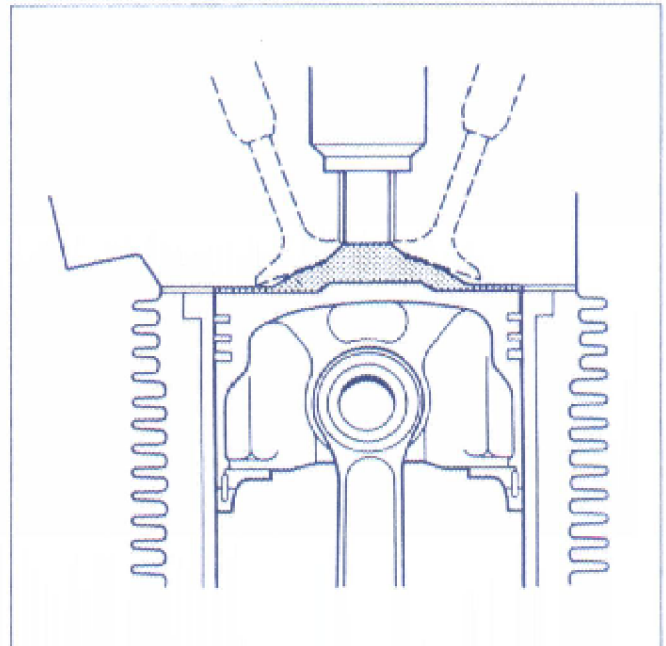

CALCULATE .

$$E = \frac{V_c + V_h}{V_c}$$

E : Compression ratio

V_c : Combustion chamber bolume

V_h : Piston displacement (187.32 CC)

COMPRESSION RATIO	COMBUSTION CHAMBER BOLUME
12.8: 1	15.9 CC
12.7: 1	16.0 CC
12.6: 1	16.1 CC
12.5: 1	16.3 CC
12.4: 1	16.4 CC
12.3: 1	16.6 CC
12.2: 1	16.7 CC
12.1: 1	16.8 CC
12.0: 1	16.9 CC
11.9: 1	17.1 CC
11.8: 1	17.3 CC
11.7: 1	17.5 CC

CARBURETOR SETTING

Set the carburetor in accordance with the conditions of the race course temperature, altitude (atmospheric pressure), etc. Various types of setting are possible by various combinations of parts.

CARBURETOR TYPE

MIKUNI VM33, FOUR
BORE SIZE: 33 mm

STANDARD SETTING

Main jet (M.J.)	*#152.5 → (N.J. #0-4) *#142.5 → (N.J. #0-8)
Main air jet (M.A.J.)	0.9 mm
Jet needle (J.N.)	6DK1-2nd
Needle jet (N.J.)	*#0-4 → (M.J. #152.5) *#0-8 → (M.J. #142.5)
Cut-away (C.A.)	1.5 mm
Pilot jet (P.J.)	#20
Pilot screw (P.S.)	1/2 turn back
Pilot air jet (P.A.J.)	2.0 mm
Float height	22.4 ± 0.5 mm

NOTE:

- * When installing the M.J. #152.5, use the N.J. #0-4.
- * When installing the M.J. #142.5, use the N.J. #0-8.

SETTING PARTS

M.J.	#142.5 #145 #147.5 #150 #152.5 #155	Leaner ↑ ↓ Richer
J.N.	1st 5th	Leaner ↑ ↓ Richer
N.J.	#0-4 #0-8	Leaner ↑ ↓ Richer
P.J.	#17.5 #20 #22.5 #25	Leaner ↑ ↓ Richer
Air funnel	30 mm : High-speed course 50 mm : Low- or Medium-speed course	

SERVICE DATA

VALVE + GUIDE

Unit: mm

ITEM	STANDARD		LIMIT
Valve diam.	IN.	26	—
	EX.	24	—
Valve lift	IN.	9.0	—
	EX.	8.5	—
Valve clearance (when cold)	IN.	0.17–0.20	—
	EX.	0.19–0.23	—
Valve guide to valve stem clearance	IN.	0.020–0.047	—
	EX.	0.040–0.067	—
Valve guide I.D.	IN. & EX.	5.000–5.012	—
Valve stem O.D.	IN.	4.965–4.980	—
	EX.	4.945–4.960	—
Valve stem runout	IN. & EX.	—	0.05
Valve seat width	IN. & EX.	0.9–1.1	—
Valve head radial runout	IN. & EX.	—	0.03
Valve spring free length (IN. & EX.)	INNER	35.68 ± 0.2	—
	OUTER	37.69 ± 0.2	—
Valve spring tension (IN. & EX.)	INNER	6.3 ± 0.6 kg at length 30.0 mm	—
	OUTER	11.6 ± 0.8kg at length 32.0 mm	—

CAMSHAFT + CYLINDER HEAD

Unit: mm

ITEM	STANDARD		LIMIT
Cam height	IN.	34.014	—
	EX.	33.725	—
Camshaft journal oil clearance	IN. & EX.	0.032–0.066	—
Camshaft journal holder I.D.	IN. & EX.	20.012–20.025	—
Camshaft journal O.D.	IN. & EX.	21.959–21.980	—
Camshaft runout	IN. & EX.	—	0.10
Cam chain 20-pitch length		—	158.0
Cam chain pin (at arrow "3")		21st pin	—
Rocker arm I.D.	IN. & EX.	12.000–12.018	—
Rocker arm shaft O.D.	IN. & EX.	11.973–11.984	—
Cylinder head distortion		—	0.20

CYLINDER + PISTON + PISTON RING

Unit: mm

ITEM	STANDARD		LIMIT
Compression ratio	Sprint	12.5 : 1	—
	Endurance	12.0 : 1	
Piston to cylinder clearance		0.05–0.06	—

ITEM	STANDARD			LIMIT
Cylinder bore	70.010 – 70.025			—
Piston diam.	69.955 – 69.970 Measure at 15 from the skirt end.			—
Cylinder distortion	—			0.20
Piston ring free end gap	1st	R	Approx. 9.1	7.3
	2nd	R	Approx. 7.5	6.0
Piston ring end gap	1st		0.1 – 0.3	0.7
	2nd		0.1 – 0.3	0.7
Piston ring to groove clearance	1st		0.02 – 0.06	—
	2nd		0.02 – 0.06	—
Piston ring groove width	1st		0.81 – 0.83	—
	2nd		1.01 – 1.03	—
	Oil		2.01 – 2.03	—
Piston ring thickness	1st		0.77 – 0.79	—
	2nd		0.97 – 0.99	—
Piston pin bore	18.002 – 18.008			—
Piston pin O.D.	17.996 – 18.000			—

CONROD + CRANKSHAFT

Unit: mm

ITEM	STANDARD	LIMIT
Conrod small end I.D	18.010 – 18.018	—
Conrod big end side clearance	0.10 – 0.20	0.30
Conrod big end width	20.95 – 21.00	—
Crank pin width	21.10 – 21.15	—
Conrod big end oil clearance	0.032 – 0.056	0.080
Crank pin O.D.	33.976 – 34.000	—
Crankshaft journal oil clearance	0.020 – 0.044	0.080
Crankshaft journal O.D.	31.976 – 32.000	—
Crankshaft thrust thickness	0.04 – 0.18	0.25
Crankshaft journal holder width	23.88 – 23.96	—
Crankshaft journal width	24.00 – 24.05	—
Crankshaft runout	—	0.05

OIL PUMP

ITEM	STANDARD	LIMIT
Oil pump reduction ratio	1.898 (75/43 x 37/34)	—
Oil pressure (at 60°C, 140°F)	Above 3.0 kg/cm ² (300 kPa) Below 6.0 kg/cm ² (600 kPa) at 3 000 r/min.	—

CLUTCH

Unit: mm

ITEM	STANDARD		LIMIT
Drive plate thickness	Dry type	1.4 – 1.6	—
	Wet type	2.72 – 2.88	—
Drive plate claw width	Wet type	15.8 – 16.0	—
Driven plate thickness	Dry type	1.0	—
	Wet type	1.6	—
Driven plate distortion	Dry type and Wet type	—	0.1
Clutch spring free length	Dry type	40.5	—
	Wet type	35.8	—
Clutch master cylinder bore	14.000 – 14.043		—
Clutch master cylinder piston diam.	13.957 – 13.984		—
Clutch release cylinder bore	38.100 – 38.162		—
Clutch release cylinder piston diam.	38.042 – 38.075		—

TRANSMISSION + DRIVE CHAIN

Unit: mm Except ratio

ITEM		SPECIFICATION	
Primary reduction ratio		1.744 (75/43)	
Final reduction ratio		3.000 (42/14)	
Gear ratios	Low	2.266 (34/15)	
	2nd	1.882 (32/17)	
	3rd	1.631 (31/19)	
	4th	1.450 (29/20)	
	5th	1.315 (25/19)	
	Top	1.200 (24/20)	
Shift fork to groove clearance	No.1, No.2 & No.3	0.1 – 0.3	
Shift fork groove width	No.1 & No.3	4.8 – 4.9	
	No.2	5.0 – 5.1	
Shift fork thickness	No.1 & No.3	4.6 – 4.7	
	No.2	4.8 – 4.9	
Drive chain	Type	TAKASAGO: RK50HFO	

CARBURETOR

ITEM		SPECIFICATION	
Carburetor type		MIKUNI VM33	
Bore size		33 mm	
Float height		22.4 ± 0.5 mm	
Main jet	(M.J.)	#142.5, #145, #147.5, #150, #152.5 and #155	
Main air jet	(M.A.J.)	0.9 mm	

ITEM		SPECIFICATION
Jet needle	(J.N.)	6DK1-1st through 5th
Needle jet	(N.J.)	O-4 and O-8
Cut-away	(C.A.)	1.5 mm
Pilot jet	(P.J.)	#17.5, #20, #22.5 and #25
Pilot screw	(P.S.)	1/2 turn back
Pilot air jet	(P.A.J.)	2.0 mm
Air funnel		30 mm and 50 mm

SERVICING INFORMATION

PISTON + CONROD + CRANKSHAFT

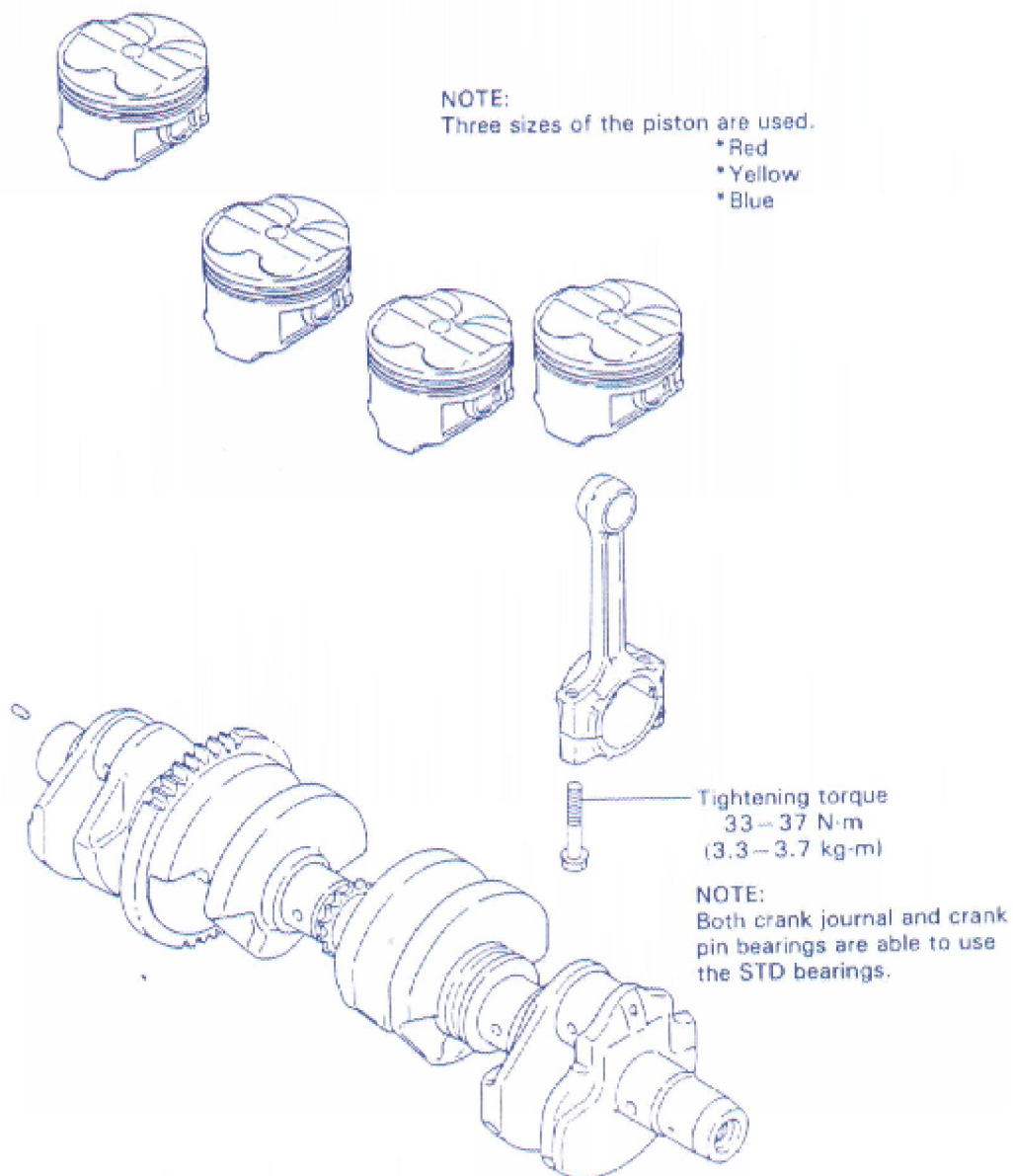

CLYINDER HEAD + CAMSHAFT

Tightening torque
8-12 N·m
(0.8-1.2 kg·m)

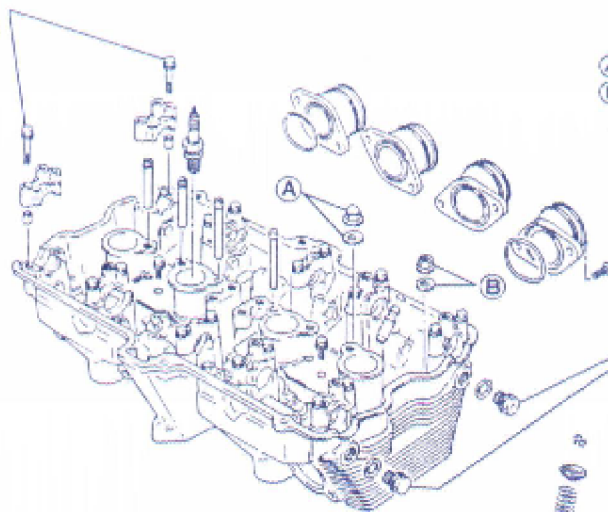

- Ⓐ Copper washer with cap nut (8 pcs)
- Ⓑ Steel washer with normal nut (4 pcs)

Tightening torque
35-40 N·m
(3.5-4.0 kg·m)

Tightening torque
25-30 N·m
(2.5-3.0 kg·m)

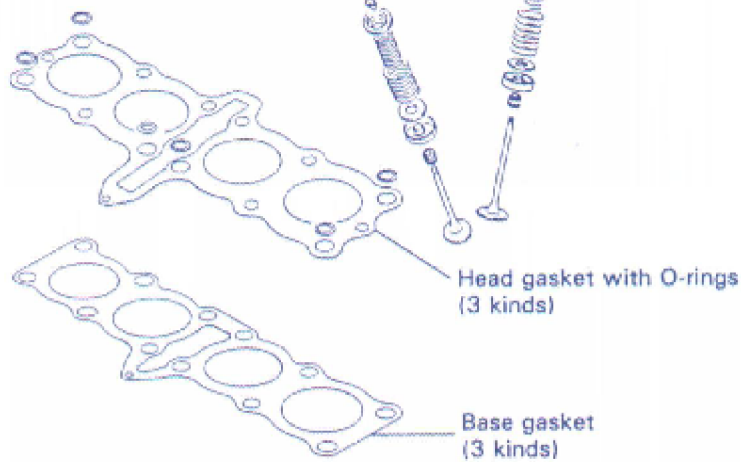

Head gasket with O-rings
(3 kinds)

Base gasket
(3 kinds)

Apply **THREAD LOCK SUPER "1303"**

Tightening torque
24-26 N·m
(2.4-2.6 kg·m)

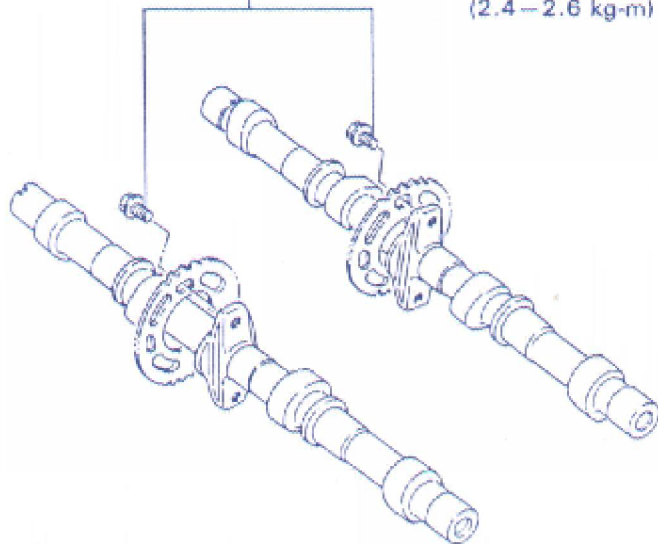

Tightening torque
8-12 N·m
(0.8-1.2 kg·m)

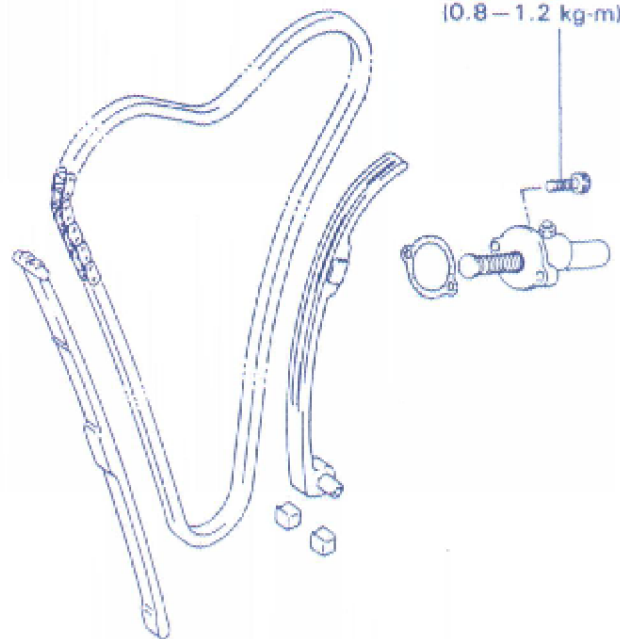

TRANSMISSION

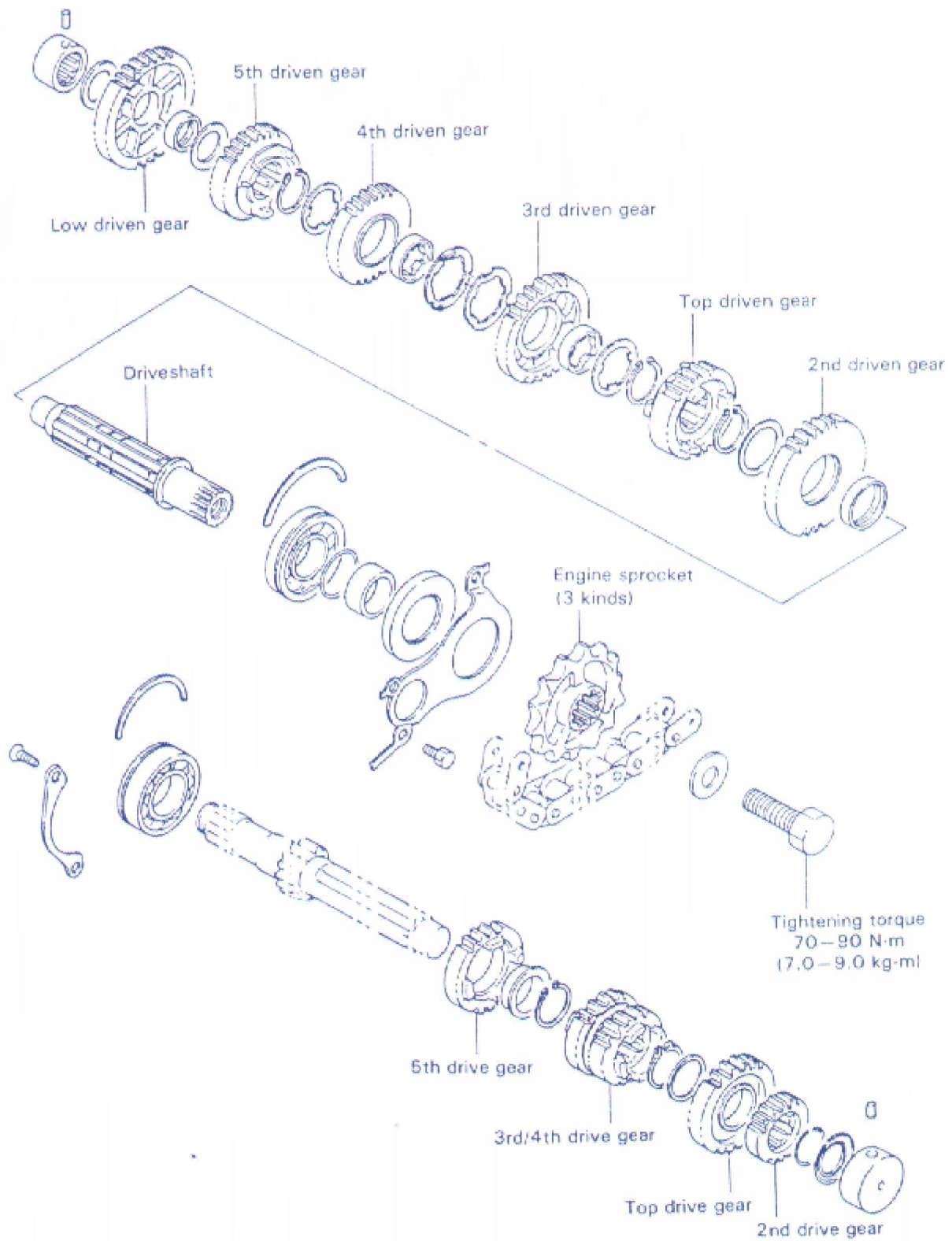

DRY CLUTCH TYPE

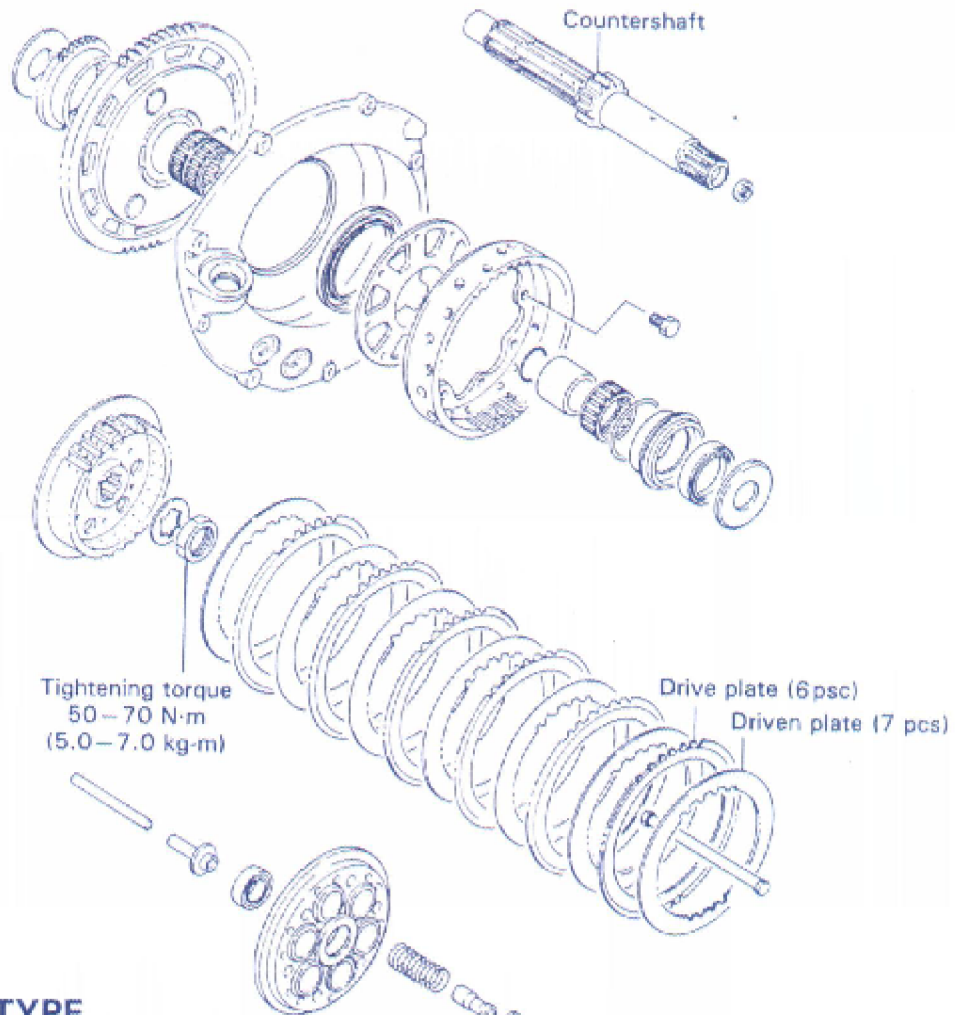

WET CLUTCH TYPE

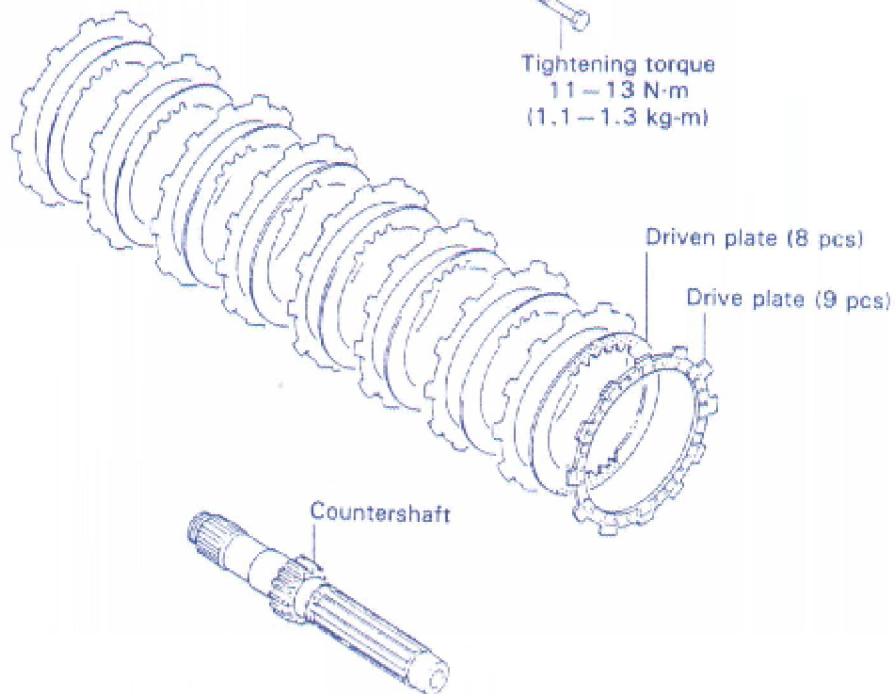

CARBURETOR

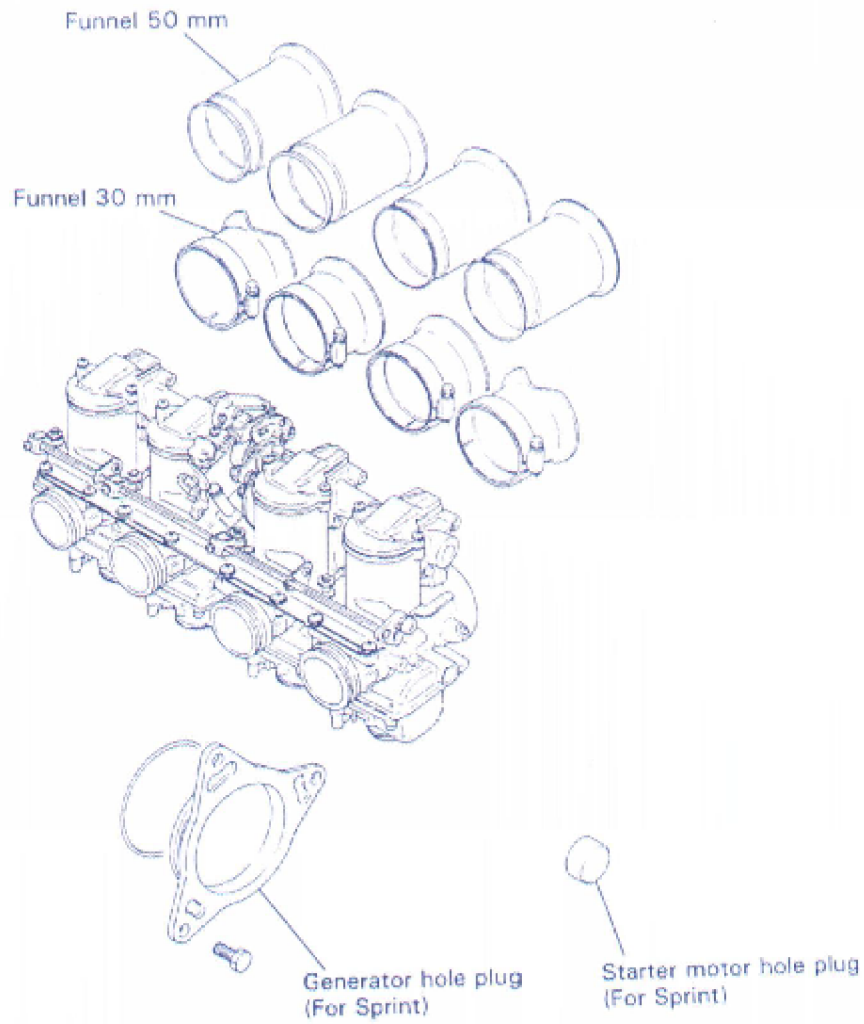

MUFFLER + IGNITOR

Ignition cut-off circuit is incorporated in the ignitor unit to prevent over-running engine.

Ignition cut-off r/min.	13,300 r/min.
-------------------------	---------------

